

MAP-ECU – Innovate LM-1 Wiring Diagram

The following diagram illustrates how an Innovate LM-1 Digital Air/Fuel Ratio Meter should be connected to a MAP-ECU to display and log AFR's on MAP-CAL:

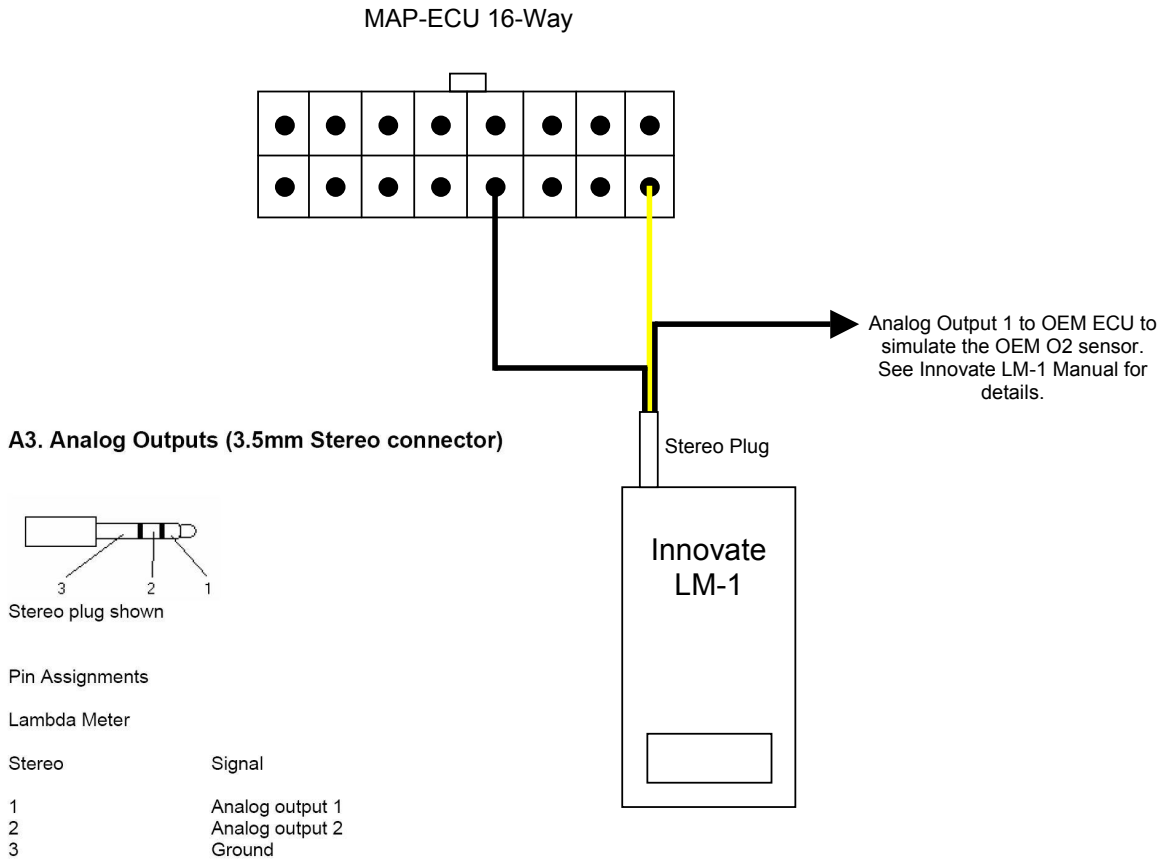

1. The MAP-ECU Yellow wire should be connected to pin 2 (Analog Output 2) and pin 3 (Ground) connected to one of the MAP-ECU Black (Ground) wires. Analog Output 2 should be configured as per the default settings of 1V=10:1 AFR and 2V=20:1 AFR.
2. MAP-CAL should be configured to use the INNOVATE.o2 or LM-1.o2 lookup table under MAP-CAL Configuration.